

Before You Construct an On-site Sewage System

Facts a homeowner should know

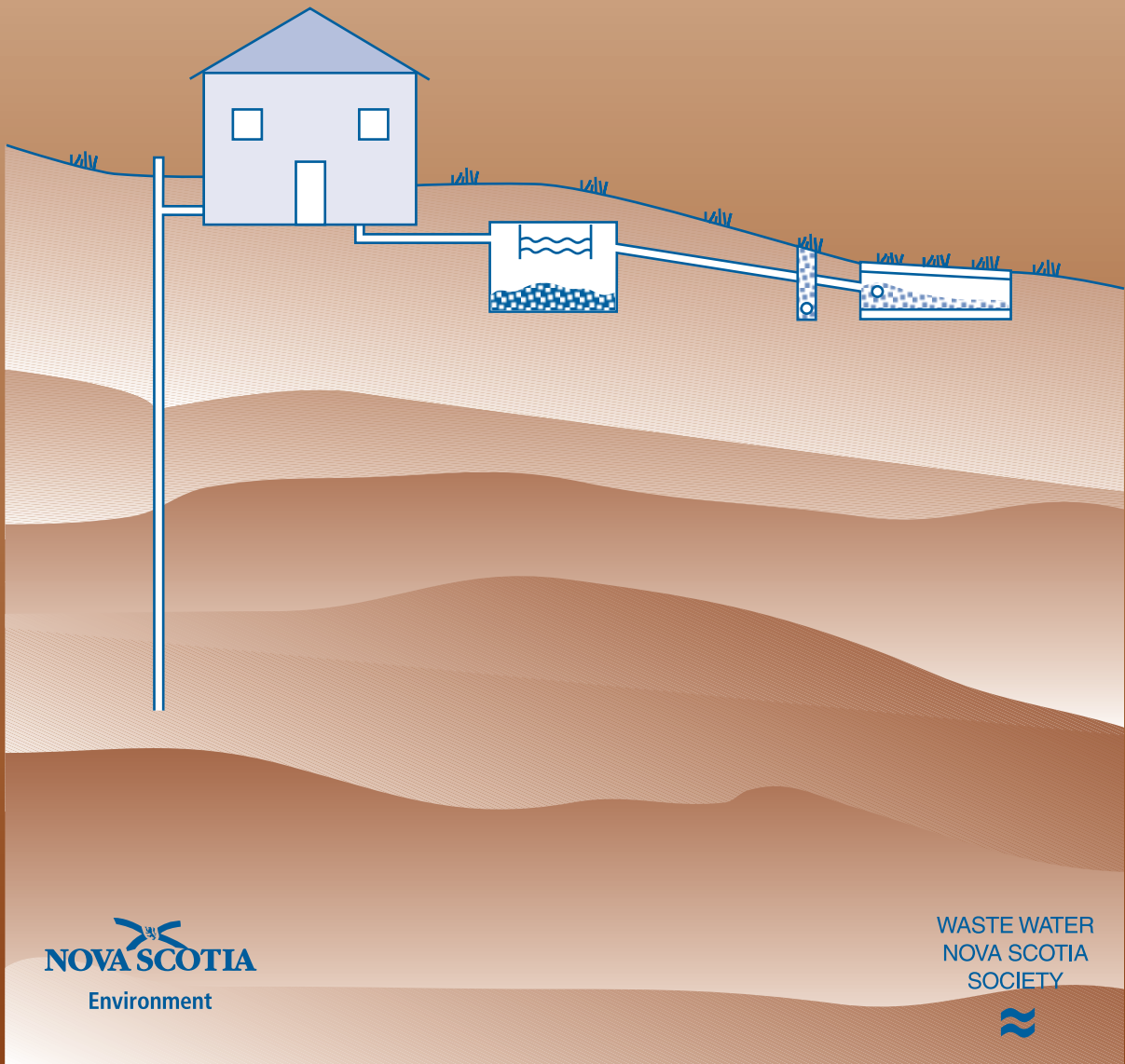

Before You Construct an On-site Sewage System

Facts a homeowner should know

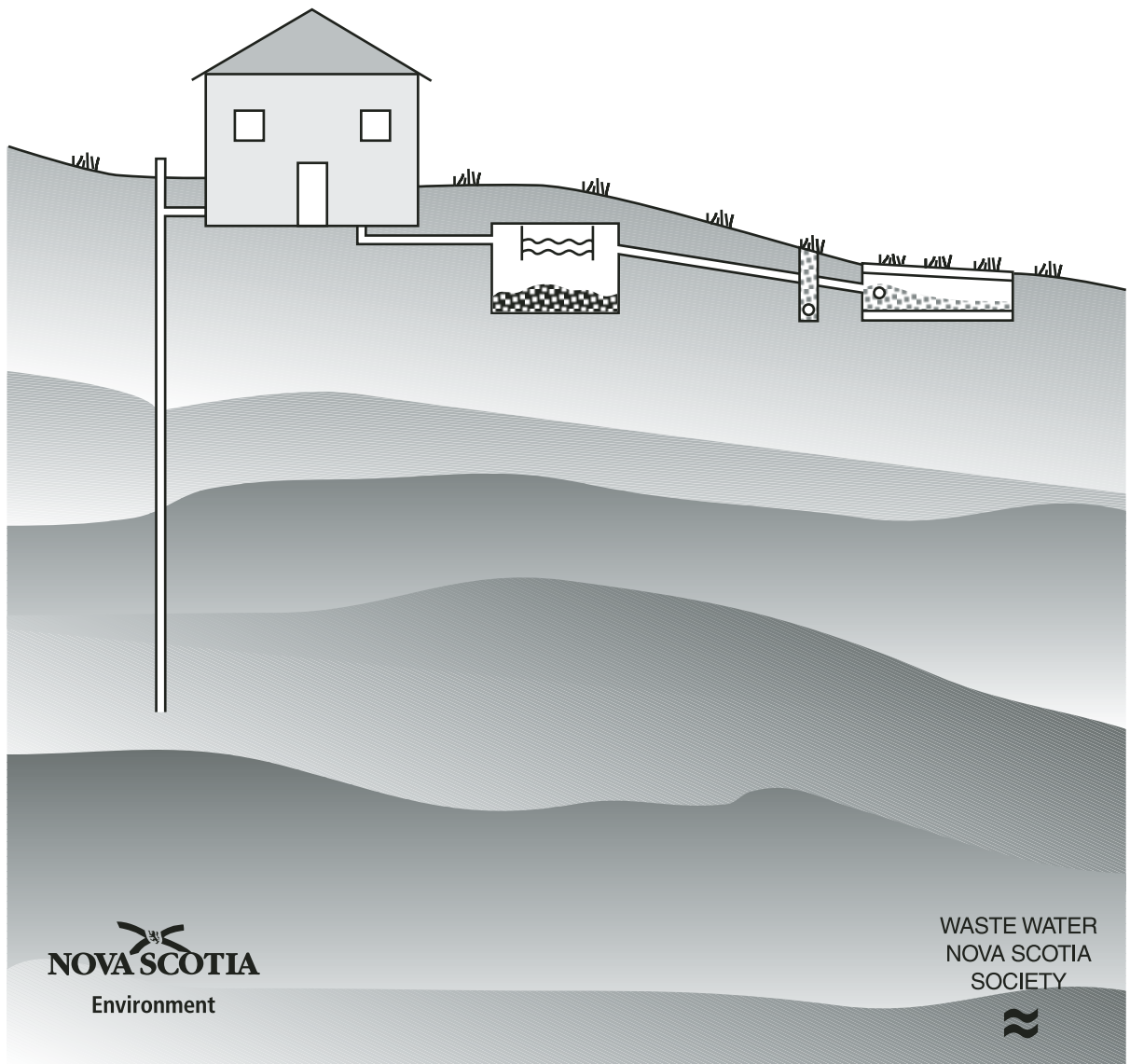

Before You Construct an On-site Sewage System

Facts a homeowner should know

Report 2000
(Second Revision 2008)



In cooperation with
Waste Water Nova Scotia Society

Halifax, Nova Scotia
2008

Preface

The cost of on-site services is usually small compared to the cost of a house or cottage, but a home is worth little without properly designed and functioning systems for disposal of wastewater and distribution of water. If you plan to build a new home or cottage, or if you plan to buy a home or cottage with an existing on-site sewage disposal system, this booklet can help you. The more familiar you are with the information in this booklet, the more likely you are to be satisfied with your system and with your home.

Nova Scotia Environment
administers the On-site Sewage
Disposal Systems Regulations.
Regional offices are listed for your
convenience at the end of this booklet.
Staff will be happy to provide you with
general information or to answer
specific questions about system
approval, construction, maintenance,
and about the regulations.

Table of Contents

An On-site Sewage Disposal System for Your Home

What is an On-site Disposal System?	1
How does a Septic Tank Work?	2
How does a Disposal Field Work?	4
What are Interceptors?	6

Planning an On-site Sewage Disposal System

Where do I Obtain Background Information for my Area?	6
What do I Have to do as a Property Owner?	7
Who are Qualified Persons?	9
What are Qualified Persons' Responsibilities?	9
What are Licensed Sewage Installers' Responsibilities?	9
What are Nova Scotia Environment's Responsibilities?	9

Contracting the Job

How do I Select a Qualified Person?	12
How do I Select An On-site Sewage Installer?	12

Buying an Existing System

How do I Locate the System if No Documents are Available? ..	13
How do I Recognize Potential Problems?	14

Caring for your On-site Sewage System

Why Should I Look After my On-site System?	14
How Should I Care for my On-site System?	14
Why and How Should I Conserve Water?	16
What Should Not Go Down the Drain?	16
What Should I Do if a Problem Occurs?	17
The House and Sewer Line	17
The Tank	17
The Field	17
How Can I Make My System Work Better?	18

Summary	20
----------------------	----

References	21
-------------------------	----

Appendix 1

- Sample Form: Application for Approval
- Sample Form: Submission Standards for Application

Appendix 2

- Sample Form: Certificate of Installation

Appendix 3

- Sample Form: Maintenance Record

Notes or Sketches**Nova Scotia Environment
Regional Offices****List of Figures**

1. Components of a Typical On-site System
2. Components of a Typical Septic Tank
3. Components of a C2 Disposal Field and Typical Interceptor/Swale
4. Approval Procedure flowchart for an On-site System
5. Example of a Septic Tank Effluent Filter System

List of Tables

1. Minimum Horizontal Clearance Distances Required
in the On-site Sewage Disposal System Regulations
2. Minimum Horizontal Clearance Distances that
Should be Maintained Where Possible
3. Minimum Clearance Distances for Wells
Some Do's and Don'ts to Keep in Mind

An On-site Sewage Disposal System for your Home

If you live in the country or a small community, or if you have a cottage or recreational property, you probably have an on-site sewage disposal system, sometimes called a septic system, and a water system from a well. These systems serve properties that are not directly connected to municipal sewer or water systems.

Nova Scotia Environment regulates the disposal of on-site sewage. Its regulations protect Public health and the environment. Department personnel administer the regulations.

Qualified Persons (QPs) in the private sector are involved in the areas of selection, design, installation, and repair of on-site systems. Information on their qualifications and responsibilities, and how to select one, is given in more detail later. Department personnel audit the work of QPs to make sure that it meets the regulations.

If you have an on-site system, this booklet will help you:

- understand how your system works
- learn how to take care of it to save you money and time.

What is an On-site Disposal System?

An on-site system is basically a recycling system that uses natural processes to treat and dispose of the 'sewage' or wastewater from normal activities in your home. A typical on-site system includes a septic tank and a disposal field (sometimes called a soil absorption area or leach field) that work

An on-site disposal system treats and disposes of wastewater from your home.

together to treat the wastewater. Figure 1 shows an example of a modern system.

Other types of systems still exist. For example, some home or cottages may have holding tanks or privies, which provide no treatment. The sewage must be pumped out frequently and treated somewhere else off-site.

The on-site system is built to handle certain types and certain amounts of wastewater. It treats both 'blackwater' (toilet wastes) and 'greywater' (wastes from the kitchen sink, bath and showers, laundry, etc.). Extra 'clear' water, from sources such as roof drains, footing and foundation drains, basement sumps, and water treatment units should not be discharged to the on-site system as this extra water does not need treatment and may overload your system. Make sure you know what your system is designed to handle. The section titled Caring for an On-site Sewage System talks about this in detail later.

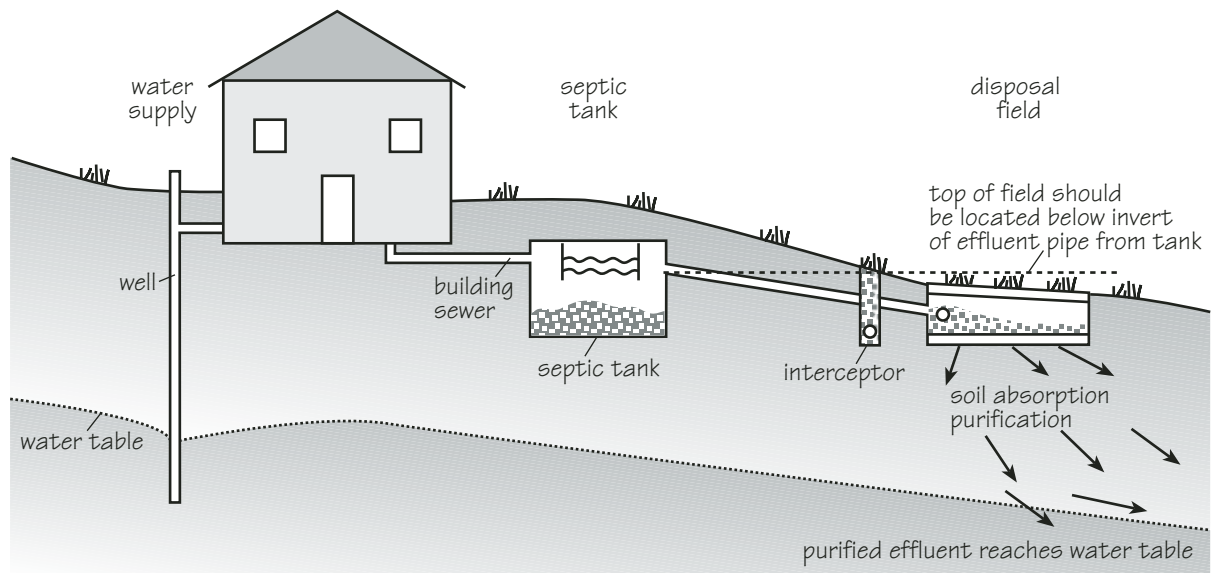

Figure 1 **Components of a Typical On-site System**

On-site disposal systems differ in detail according to local site conditions, but all must meet specifications of Nova Scotia Environment. When properly designed, installed, used, and maintained, your system will be simple, economical, and effective, and will do its work reliably, safely, and efficiently for many years. If it is poorly designed or installed, or if you use it improperly or do not take care of it, your system can fail. If it fails, it could:

- contaminate a water supply or water used for human consumption
- contaminate a watercourse, wetland, or marine water body
- harm human health.

Also, if it fails, repairs could cost you a great deal.

How Does a Septic Tank Work?

Wastewater from the house usually flows by gravity through a building sewer pipe into the septic tank as shown in Figure 1. In some types of systems wastewater is pumped from the house to the tank.

The tank must resist corrosion. Acceptable materials include reinforced concrete, fibreglass, or polyethylene. Tanks that are made of steel corrode over time. If you have a steel tank, you should plan to replace it. The tank must conform to Canadian Standards Association CAN/CSA-B66-M90 (or the most recent update).

The tank must be water tight. It must have an access so that it can be maintained, inspected, and pumped out. The access cover must be water tight and secure to keep unauthorized persons and children out, and to minimize health and safety hazards.

The tank is designed to store the wastewater for a day or more before discharging it to the disposal field or to further treatment. During this time, the

The septic tank holds sewage long enough for solids to settle or float, and for bacteria to break down some of the solids naturally.

heavier sewage solids settle to the bottom to form a **sludge** layer. Lighter solids, fats, greases, and oils float to the top to form a **scum** layer on top of the water. This leaves a middle layer of partially clarified liquid wastewater as shown in Figure 2.

The storage time serves two purposes:

- It allows the solids and liquid to separate, which prevents the solids from being carried into the disposal field and clogging the field and surrounding soil.
- It allows time for bacteria naturally found in the wastewater to break down or digest the solids. This process takes place without the presence of oxygen, and produces gases that must be vented from the tank. Since bacteria reduce the amount of sludge and scum by less than half (approximately 40 per cent), the tank must be pumped regularly to remove the rest of the solids.

An outlet baffle in the septic tank allows only the partially clarified liquid in the middle layer to leave the tank. This liquid is called effluent. It still contains bacteria, suspended and dissolved organic solids, and other materials that can be dangerous to health and to the environment. The **effluent** is discharged to the **disposal field**, which distributes it into the soil for further treatment and disposal.

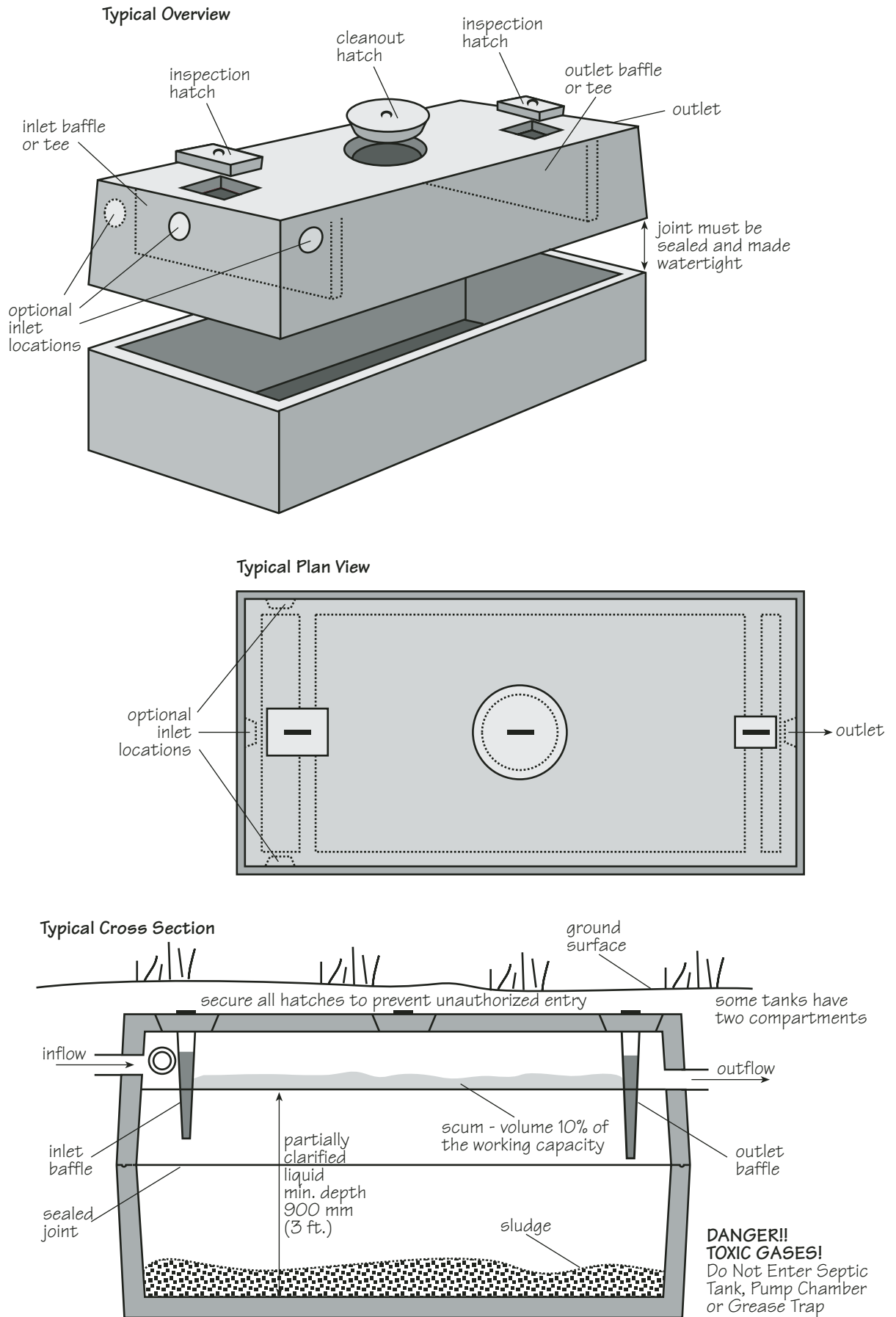

Figure 2 **Components of a Typical Septic Tank**

How Does a Disposal Field Work?

Effluent normally flows from the septic tank to the disposal field by gravity because the water level in the tank is higher than the level in the field. Distribution pipes to the field are watertight. The pipes within the field are made of perforated PVC or ABS plastic pipe. Longer systems or systems that cannot be gravity fed need siphons or pumps and pressure distribution piping to distribute effluent evenly into all parts of the disposal system.

The disposal field distributes the effluent evenly at a rate at which the soil can accept the liquid.

Disposal fields consist of several components (Figure 3), each with a different job.

- **Sod:** protects against frost and erosion, sheds surface water, and stores surface water that soaks in until it evaporates or is used by plants.
- **Clean local fill or imported sand fill:** supports the sod and helps its work, and allows oxygen and other gases to pass into and out of the disposal field. If imported sand fill is required, it must meet specific permeability and size requirements.
- **Geotextile (synthetic barrier material):** prevents the backfill material from moving down into the crushed rock and clogging the openings between the rock particles.
- **Perforated distribution pipe:** distributes the effluent evenly to all parts of the field through regularly spaced holes.
- **Crushed rock:** surrounds and protects the pipe, and stores and distributes the effluent over the disposal area.
- **Filter sand:** provides a place at the boundary between the sand and crushed rock for a biological clogging mat which will form after a number of months of operation. This sand must meet specific permeability and size requirements.

- **Natural soil:** acts as the final filter to remove harmful organisms before the effluent reaches groundwater, which may supply a well or discharge into a stream or lake.

As the effluent trickles slowly from the pipes into the field, and eventually into the natural soil, the components of the field and the associated soil microorganisms work together to treat the wastewater. Harmful bacteria are physically filtered out and also destroyed by soil microorganisms. Some dissolved components in the effluent are taken up by plants, adsorb (stick) to soil particles, or are broken down by soil bacteria. When the effluent finally leaves the system, it should not harm public health or the environment.

There are various types of disposal field designs, depending on site conditions. A qualified person evaluates the conditions when selecting or designing a system. Most systems now installed are contour (C1, C1 raised, C2, C2 raised, C3, and mound) types. Figure 3 shows an example of a C2 system. Older systems were usually area bed or multiple-trench type.

For all systems, regulations specify that a minimum thickness of unsaturated soil must be maintained between the bottom of the disposal field and water table, bedrock, or other features that may limit proper movement or filtering of the effluent (Figure 3). If the natural soil is

The soil and its microorganisms work together to turn effluent into clean water.

too coarse to protect the groundwater, a built-up disposal system with an additional layer of imported sand fill is required over the coarse soil. If the natural soil is too fine

to allow vertical movement of effluent, imported sand fill must be brought in to provide an adequate distribution area.

Elevation

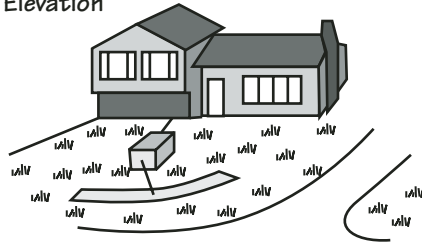

Contour System, Plan View

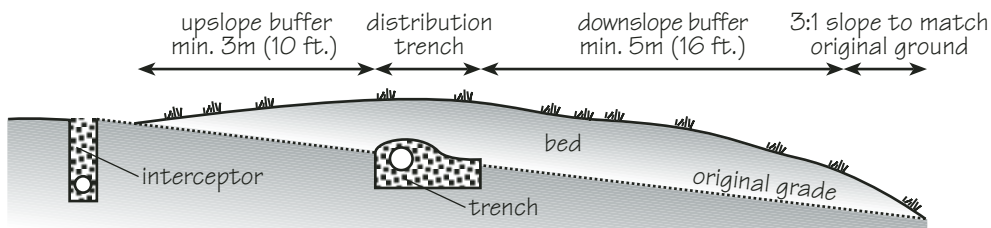
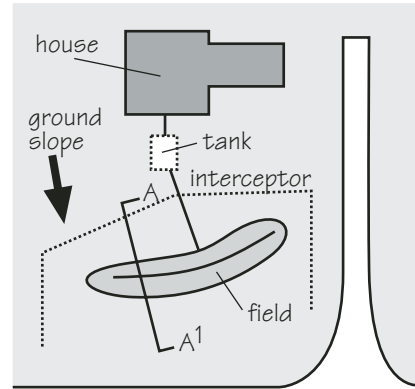

Cross Section A-A¹ Schematic, C2 System

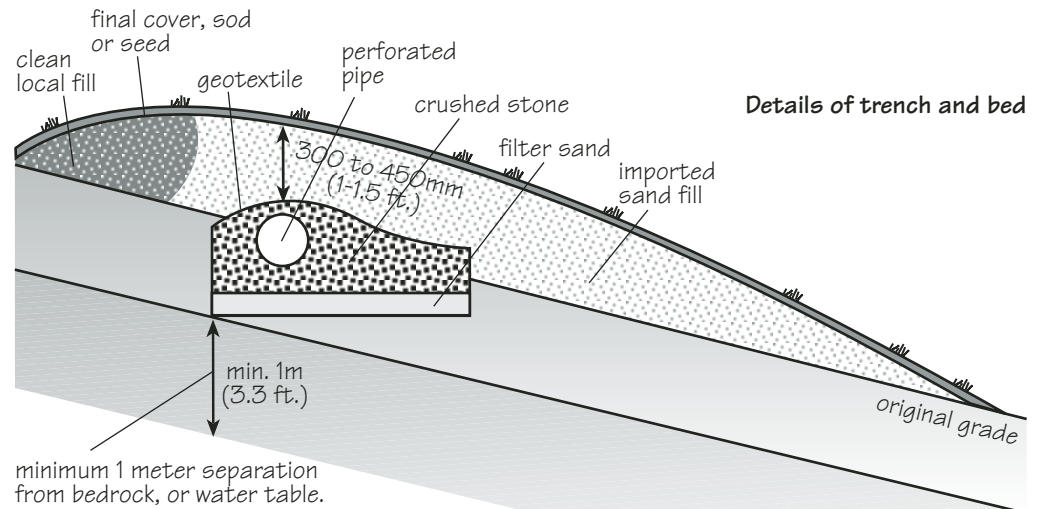

Details of Interceptor/Swale

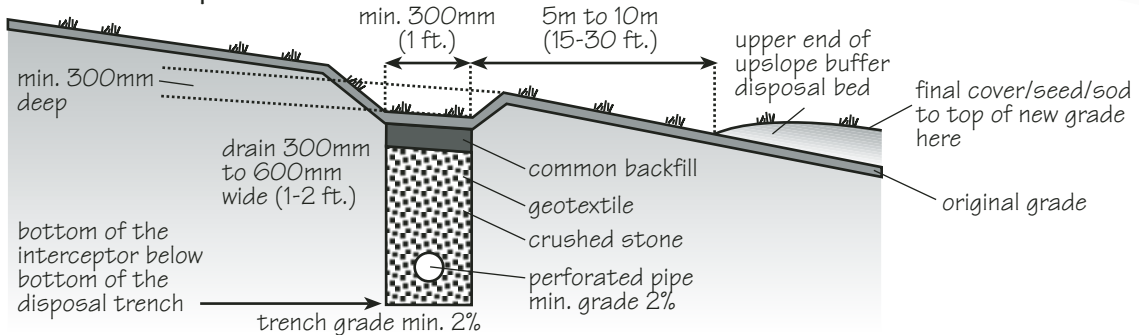

Figure 3 Components of a C2 Disposal Field and Typical Interceptor/Swale

Most of all the effluent will eventually reach the water tables. Systems are designed to ensure that effluent is properly treated in the field and natural

The effluent will be properly treated if the system is kept in good working order and is not overloaded.

soil and that harmful bacteria are removed before it reaches the water table beneath the disposal field. In cases where effluent moves laterally, the natural soil or imported fill or both should provide enough treatment. Also, the area immediately

downslope of a system should be covered with grass or natural vegetation to allow the treated effluent to travel in the root zone and not on the ground surface.

What are Interceptors?

Interceptor drains intercept and divert surface water and shallow groundwater upslope of a disposal field. They help to prevent soil erosion and field waterlogging. Interceptors are not required on all lots. An interceptor can be a swale (shallow trench) at the ground surface, or it can be a trench filled with crushed rock and containing a perforated pipe, as shown in Figure 3.

Foundation and roof drainage should be directed away from a disposal field. This drainage should not be connected to the drain, although the pipe may be laid in the same trench as the interceptor.

Detailed technical information about on-site systems is available. Copies of the Technical Guidelines can be purchased from Nova Scotia Environment or view it on the Departments website.

Planning an On-site Sewage Disposal System

If you are looking for a lot, remember before you buy that steep slopes, bedrock, streams, water bodies,

If you are looking for a lot, check background information for the area.

and marshes may cause construction and drainage problems. On-site systems on such lots are likely to cost more. Before finalizing any purchase, check available information.

Where Do I Obtain Background Information for My Area?

The type of material beneath the ground surface in your area (soil and surficial geology mapping) can provide you with a general idea of soil permeability. Maps are available from various government agencies. The following people can also provide you with helpful information:

- **Local qualified persons and installers.** Drawing on their experience in the area, QPs and contractors can supply information on the procedure for selecting/designing an on-site system.
- **Nova Scotia Environment.** Staff can provide information on geology, general information respecting on-site systems in the area, and the procedure and approvals required to construct an on-site system.
- **Nearby homeowners.** Ask them about their onsite systems.

If you already have a lot, **plan** what the completed lot will look like before you start to build. Each lot

If you have a lot, know the regulatory requirements and plan ahead.

must be assessed individually to determine the soil conditions where the disposal field is to be located. Soil conditions can vary widely, even over the area of one lot. All

buildings and on-site services must meet applicable regulations. For example, horizontal separation distances to wells, streams, property lines, and other features are regulated and are designed to minimize adverse environmental effects. A qualified person (QP) will assess the lot and make sure regulations are followed before seeking an approval.

What Do I Have to do as A Property Owner?

A general overview of the start-to-finish procedure to obtain an approved system is outlined below and summarized in Figure 4. You do NOT have to carry out all these steps yourself, but as a property owner you ARE responsible to see that they are done:

Assessment

- Get an application for approval form and a list of QPs from your nearest Nova Scotia Environment office (locations are listed in the back of this booklet). Appendix 1 shows an example of the form.
- Hire a QP (see the following section to find out who qualifies) who will assess the property, select or design a system, and complete and sign the application form. You must also sign the form.

Application

- Mail or drop off the completed application form to the local Nova Scotia Environment office yourself, or have your agent do so. The department charges an administration fee for each application.
- Processing will normally take a few days while staff review the application; they may visit the site. If the information on the completed form is satisfactory, approval for installation will be given for the system selected or designed by the QP. If the application is incomplete, it will be returned with a letter outlining what is missing. The process will begin again once the corrected form is submitted.

- When approved, one copy will be returned to the applicant, or the applicant contact person (as indicated on application for approval). Nova Scotia Environment will keep the original copy. Municipalities may request a copy of the approval before they will issue you a building permit.

Installation

- You or your agent then hires a certified installer to install the system according to the terms and conditions specified on the approval.

Inspection

- Your QP must verify that the installation meets the terms and conditions of the approval. Nova Scotia Environment must be notified three days before the system is covered so that an inspector can check the installation if they wish.
- Spread final cover material over the disposal field immediately and seed or sod to prevent erosion. This will be one of the terms and conditions of the approval. Your QP will do another inspection to ensure that final cover is placed.
- After the final inspection and covering of the system, the QP must complete a "Certificate of Installation Form." This form is signed by both the QP and the installer. The installer will also complete the, "Completion of Work Form for On-site Sewage Disposal System Installers." (Sample form in Appendix 4).

Final details

- The QP distributes copies of the certificate of installation and the completion of work form to you as the owner, Nova Scotia Environment, and the local municipal office.

Once the system is installed, you as the homeowner or applicant have the biggest role in keeping it working. Four ways to do this are:

- Make sure that the cover material and seed or sod cover is in place.
- Make sure that you know where the septic tank, its covers, and the disposal system are located for future maintenance. Make sure that landscapers who work on the property later know where all parts of the on-site system are located so that they don't disturb it or drive over it.
- Make sure that the interceptor drains are maintained and not filled in, redirected, or otherwise destroyed by later landscaping.

- Make sure that the system is properly maintained as outlined later in this booklet.

Finally, make sure your paperwork is in order. Keep certificates, measurements, diagrams or sketches, and other information related to the system with your deed or in a separate, readily accessible onsite services folder. If you sell the property later, make sure that the information is given to the next owner.



Figure 4 **Approval Procedure Flowchart for an On-site System**

Who Are Qualified Persons?

Qualified persons (QPs) can select or design a system for you. System selection involves choosing a system from Nova Scotia Environment's technical guidelines if site conditions, such as soil type, slope, depth to water table, and depth to bedrock, match those in the guidelines. System design involves making changes to the systems in the guidelines, if site conditions do not match those exactly, or for larger systems, or for modifications other than emergency repairs to existing systems. There are two types of QPs:

- Qualified Persons Level I (QPIs) can select or design systems. QPIs are professional engineers who are registered to practice in Nova Scotia and who hold valid liability insurance.
- Qualified Persons Level II (QPILs) can select systems, but not design them. QPILs are technical persons other than professional engineers who hold valid liability insurance, and who have been properly trained and certified.

There is a section later on how to select a QP.

What Are Qualified Persons' Responsibilities?

Under the regulations, QPs must provide information to Nova Scotia Environment as part of the application for approval (sample form in Appendix 1). At the appropriate time, the QP performs the final inspection of the system and submits additional information as part of the certificate of installation (sample form in Appendix 2).

Lot layout requires careful planning to ensure that all regulatory and recommended separation distances are maintained. For your information, these distances are summarized in Tables 1 and 2 on pages 10 and 11. The well location must also meet separation distances required by the Well Construction Regulations, summarized in Table 3 on page 11. Your QP is responsible to ensure that your system is properly located and installed according to regulations.

What Are Licensed Sewage Installers' Responsibilities?

Certified installers have the following responsibilities:

- Make sure that a valid approval (Appendix 1) exists for the on-site sewage disposal system before installation.
- Make sure that the exact contour is followed.
- Make sure that septic tank, fill, pipe, and geotextile meet regulatory specifications.
- Install the system according to the approval obtained.
- Contact Nova Scotia Environment before any variation is made to an approval.
- Contact the QP for an inspection before covering the sewage disposal system.
- Cover septic tank with 15–150 cm (6–60 in.) of soil.
- Cover disposal system with 30–46 cm (12–18 in.) of approved sand, and cover sand with 10–15 cm (4–6 in.) of final cover material.

What Are Nova Scotia Environment's Responsibilities?

Design, selection, construction, and ownership of an on-site sewage system are governed by the Environment Act and the On-site Sewage Disposal Regulations. Anyone found violating the act and/or regulations is subject to prosecution under the Summary Offence Act. If convicted, they could be fined. You can view the regulations at your local Nova Scotia Environment office, or download them from the web:

<http://www.gov.ns.ca/just/regulations/regs/ENV-On-siteSewageDisposalSystems.htm>

The department and its Inspector Specialists have the following responsibilities with respect to on-site systems:

- Provide lot/subdivision information to the public.
- Review the applications submitted by QPs to ensure that all information is included and that selections/ designs follow approved standards and guidelines.
- Audit all aspects of the process through to installation, including field inspections if necessary.
- Assist and guide newly certified QPs with the entire process through a mentoring program to make sure that the work is done to standards. Enforce the department's regulations respecting on-site sewage disposal systems.

Table 1 **Minimum Horizontal Clearance Distances Required by the On-site Sewage Disposal System Regulations¹**

From	To	Distance (metres)	Distance (feet)
System, including septic tank and disposal field ⁶ , holding tank or privy	Any lot boundary	3	10
	Lot boundary downslope from disposal field	9	30
	Drilled well with at least 6.1 m (20 ft) of casing ²	15.2	50
	Dug well ^{2,3} or any other water supply	30.5	100
	Watercourse ⁴ or wetland ⁵ or marine waterbody (A septic tank may be 15.2 m (50ft) from a watercourse or marine water body.)	30.5	100
	Downslope ditch or drain that flows intermittently, except drains or ditches that form an integral part of the system	15	50
	Municipal or private water distribution system (A septic tank may be 3 m (10ft) from a municipal or private water distribution system)	6	20
	Artificially created body of water	15	50
Disposal Field ⁶	Cistern (A septic tank may be 5 m (16ft) from a cistern.)	8	25
	Minimum vertical separation distance between the bottom of the disposal field and any bedrock, maximum groundwater table, or any other limiting conditions ⁸	1	3.3
Septic tank, vault privy, or holding tank	Foundation drainage system ⁹	1.5	5
Disposal field or pit privy down slope.	Foundation drainage system ⁹	6	20

Notes:

- (1) An inspector may require greater distances if adverse effects may be created, and shall provide reasons in writing.
- (2) See also Tables 2 and 3, and note 7 below.
- (3) A dug well includes a drilled well with less than 6.1 m (20 ft) of casing.
- (4) Watercourse means the bed and shore of every river, stream, lake, creek, pond, spring, lagoon or other natural body of water, and the water therein, within the jurisdiction of the Province, whether it contains water at all times or not.
- (5) Wetland means land commonly referred to as a marsh, swamp, fen or bog that either periodically or permanently has a water table at, near or above the land's surface or that is saturated with water, and sustains aquatic processes as indicated by the presence of poorly drained soils, hydrophytic vegetation and biological activities adapted to wet conditions.
- (6) Separation from disposal field should be measured from nearest edge of the trench.
- (7) Whenever possible, disposal systems should not be located immediately upslope of wells. When planning proposed subdivision layouts, it is important to consider relative locations of wells and disposal systems to avoid problems as lots become developed.
- (8) A perched water table is considered a limiting condition.
- (9) Foundation drainage system includes both the system around the home AND the discharge pipe, whether perforated or not.

Table 2 **Minimum Horizontal Clearance Distances that Should be Maintained Where Possible¹**

From	To	Distance (metres)	Distance (feet)
Disposal field ⁴	Downslope boundary or a lot with a depth of permeable soils of:		
	• 300-600mm	15	50
	• 150-299mm	25	82
	• 0-149mm	30	100
	Downslope sudden increase or break in slope on a lot with a depth of permeable soils of:		
	• 601mm and deeper	5	16
	• 300-600mm	10	33
	• 150-299mm	15	50
	• 0-149mm	20	66
	Wells immediately downslope ^{3,5}	100	330
Downslope foundation	20	66	

Notes:

- (1) An inspector may require greater distances if adverse effects may be created, and shall provide reasons in writing.
- (2) Amount of permeable soil on a lot determines its area and minimum width. Lot size is NOT related to the type of system (C1, C2, etc.). Lot size is determined by soil type, permeability and depth, whether any part of the system will be within 60 m (200 ft) of water (lake, stream, river, ocean), and the maximum daily flow. Lot area and width may be increased when flows exceed 1500 litres per day (330 gallons per day).
- (3) A dug well includes a drilled well with less than 6.1 m (20 ft) of casing.
- (4) Separation from disposal field should be measured from nearest edge of the trench.
- (5) Whenever possible, disposal systems should not be located immediately upslope of wells. When planning proposed subdivision layouts, it is important to consider relative locations of wells and disposal systems to avoid problems as more lots become developed.

Table 3 **Minimum Clearance Distances for Wells^{1,2}**

From	To	Distance (metres)	Distance (feet)
Cesspool (receiving raw sewage)	Drilled or dug well	61	200
On-site sewage disposal system, sewer of tightly joined tile or equivalent material, sewer-connected foundation, floor drain, or water treatment discharge point	Drilled well	15.2	50
	Dug well	30.5	100
Sewer with secondary containment, roof drainage discharge point, non-sewer connective foundation, or floor drain, or cistern	Drilled or dug well	3	10
Pumphouse floor drain	Drilled or dug well	610 mm	2
Outer boundary of any public road or public highway	Drilled or dug well	6.1	20
Landfill, former dump site or other significant source of contamination (if written approval is granted for well construction)	Drilled or dug well	61	200
Above ground petroleum storage tank system with a capacity of 1200 L or less	Drilled well	5	16
	Dug well	15.2	50
Above ground petroleum storage tank system with a capacity of greater than 1200 L	Drilled or dug well	15.2	50
Underground petroleum storage tank system	Drilled or dug well	15.2	50

Notes:

- (1) See also note (5) in Table 2.
- (2) A dug well includes a drilled well with less than 6.1 m (20 ft) of casing.

Contracting the Job

How do I Select a Qualified Person?

- ✓ Does the QPI have a valid licence from Association of Professional Engineers of Nova Scotia?
- ✓ Does the QPII have a valid certificate of qualification from Nova Scotia Environment?
- ✓ Does the QP (I or II) have appropriate liability insurance?

A list of QPs can be obtained from your local Nova Scotia Environment office or web page
<http://www.gov.ns.ca/enla/water/onsitesewage.asp>

How Do I Select An On-site Sewage Installer?

Under the On-site Sewage Regulations, any person constructing or repairing on-site systems must have an up-to-date certificate of qualification from Nova Scotia Environment. The certificate is renewed every year.

Nova Scotia has many certified installers. Most operate within a one- to three-county radius. Experienced contractors who have worked in the area will be most familiar with local conditions.

Prior to selecting a contractor for the job, it is a good idea to obtain information from and about several contractors.

Check for the following:

- ✓ Does the contractor have a valid certificate of qualification from Nova Scotia Environment?
- ✓ Does the contractor have adequate equipment in good condition to do the job?
- ✓ Does the contractor have adequate liability and worker's compensation insurance to protect you?
- ✓ Is the contractor familiar with applicable occupational health and safety codes?
- ✓ What is the contractor's reputation with previous customers?

Once the contractor is selected, keep in mind that:

- If terms and conditions of the approval must be changed due to unforeseen problems or conditions encountered during construction, discuss the options with your QP and the contractor. **Approval for any changes must be obtained from Nova Scotia Environment.**
- Changes may mean additional costs.

Any person constructing or installing or repairing on-site systems must have a valid certificate of qualification from Nova Scotia Environment. Every septic tank cleaner must have a valid certificate of qualification.

Buying an Existing System

For a house purchase, banks and mortgage companies now usually request a certificate from a QP that the on-site system was installed according to Nova Scotia Environment standards, or a copy of the certificate of installation showing details of the on-site system (Appendix 2). Houses built before 1985 may not have certificates, and records prior to 1995 are poor. In short, the responsibility is YOURS.

Before buying an existing home, you should check the following:

- Find out where the existing wastewater system and water supply are located and get complete information about them before completing the purchase. Inspection by a trained person is strongly recommended, especially if little or no information or documentation is available.
- Find out exactly where property boundaries are and be sure there is enough room to replace or modify wastewater systems if necessary.

Ask for answers to a few important questions such as:

- How old is the system?
- When was the septic tank last pumped?
- How frequently has it been pumped?
- Have there been signs of possible failure?

How do I Locate the System if No Documents are Available?

Contact your local Nova Scotia Environment or municipal office and ask if there is a copy of the approval for your property on file. Before calling, know the previous owner's name, approximate dates the current system was installed, and a civic address. If there is no information on file:

- Look in the crawl space or basement area to see the direction in which the building sewer pipe enters the soil. Measure the distance from the sewer pipe to the corner of the outside wall from inside the house, then the same distance along the same wall on the outside of the house.
- Locate the septic tank by pushing a thin (1.0 to 1.3 cm (3/8 to 1/2 in.) diameter) steel rod into the soil to feel for the tank, which is usually about 3 m (10 ft) from the house and 0.6–0.9 m (2–3 ft) below ground surface. Before digging or probing, call Nova Scotia Power Inc. at 1-800-428-6230 to make sure that there are no underground utilities such as buried electrical cables in the area. Be careful of overhead utility lines as well.
- To locate an older area bed disposal field, start searching downslope from the septic tank. If the system has a pump, the field can be upgradient of the tank, but this situation is not common. Probe the ground every couple of feet with an insulated probe until you hear the metal rod contact gravel or the probe is wet (when test is not during a rainy period), and flag that point. Repeat to locate additional drain field lines (usually 0.9–1.5 m or 3–5 ft apart and 15–30 m or 50–100 ft in length). Take careful measurements and sketch locations on a grid or graph paper for future reference. Pages are included for this purpose.

Some manufacturers and consultants offer electronic transmitters and sonar to assist with locating the septic tank. Metal detectors are another possibility with old systems or metal tanks.

How Do I Recognize Potential Problems?

Although not foolproof, some possible warning signs of a system that is not working properly include:

- plumbing backups or sewage backups in the house (toilets, drains, etc.)
- toilets that take longer to flush, showers and sinks that take longer to drain. Flush each toilet to observe whether it drains quickly or not. Run water in every sink and observe whether it drains freely or sluggishly. If only one fixture is slow, the problem is likely related to that individual fixture.
- gurgling in the plumbing
- breakouts or discharge of raw sewage to the ground surface, especially after a heavy rainfall. Breakouts are often indicated by wet spots or ponding or grey or black liquids or black soil areas in the area of the disposal field or nearby ditches
- noticeable unpleasant or sewage odors around the yard, or in the vicinity of the disposal field, especially after a rainfall.
- lush green growth over the disposal field. Grass over the system becomes unusually green or spongy to walk on, even during dry weather.
- buildup of aquatic weeds or algae in lakes or ponds or ditches adjacent to your home.
- the presence of nitrates or bacteria in the well water. It is wise to have the well water tested for bacterial and chemical quality, as recommended in the companion booklet Before You Construct a Water Well.

If you notice any of the signs above, get professional advice before finalizing the purchase. Repairs or replacement, if necessary can be costly.

Caring for Your On-site Sewage System

Why Should I Look After My On-site System?

On-site systems are generally cheaper to install and maintain than central services, but they do require more care and attention by the owner. When properly installed and looked after, on-site systems

A well-maintained septic system can run for decades.

An abused or neglected one can fail tomorrow.

can reliably dispose of household sewage in a way that will protect your water supply, public health, and the environment.

Improperly designed, selected, installed or maintained systems can fail.

Repair or replacement of a failed on-site system is expensive. Cutting costs in the care or maintenance of your system, or careless use of a system, will usually cost you more in the long run. A poorly maintained or malfunctioning system can reduce the resale value of your property.

How Should I Care for My On-site System

Solids accumulate in a septic tank over time. When a tank is allowed to fill near or past its capacity, sludge or excess solids can migrate into the disposal field and block the pipes. The tank inlet may also get blocked, and cause sewage back up into the home. Repairs can range from clearing a few lines to replacing entire disposal fields and landfilling contaminated soil. Costs can vary from a few hundred to a few thousand dollars.

Inspect the tank every year or two and have it pumped regularly, at least every 3 years. Have the tank pumped by a septic tank cleaner who has a valid certificate of qualification.

The tank should be pumped out to remove solids every 3 years, or when required, depending on the amount of use and the type of materials that enter the system. Regular inspection may indicate that an individual tank can be pumped less frequently, while tanks that are heavily used or abused may need to be pumped more often. The average septic tank should be inspected every 1-2 years by a professional septic tank cleaner. If the cover is removed and the tank is full, this does not mean there is a malfunction. The tank is designed to have the outflow level approximately 75 mm (3 in.) Below the inflow level.

- If the distance between the bottom of the pipe coming from the house and the liquid level is greater than this, then the liquid in the tank is leaving the tank somewhere other than the pipe leading to the disposal field.
- If the distance between the bottom of the pipe coming from the house and the liquid level is greater than the liquid in the tank is leaving the tank somewhere other than the pipe leading to the disposal field.

Grease traps should be inspected regularly. If the grease chamber is half-full, the tank should be pumped by a certified septic tank cleaner. After you uncover the tank, the septic tank cleaner will pump the contents into a truck and dispose of it in an approved manner. The tank should not be washed or disinfected. Operation of pumps and siphons should be routinely checked by a certified person.

Summer and early fall are the best times to pump out a regularly used septic tank. This will leave time before winter for the tank to refill and for bacterial action to re-establish. Also, in the fall the ground will not be frozen, and a high water table, which can create buoyancy problems for septic tanks, is usually not a factor. Tanks in seasonal systems should not be emptied before winter because they may be damaged by frost.

Septic tanks are often not maintained either because the location of the tank is unknown or it is so deeply buried that access is difficult. If no records are available, measure and record the location of the tank covers with reference to the corners of the house next time the tank is serviced. If access is deep, a riser with watertight joint can be installed over the manhole of the tank to bring the

NEVER enter an empty septic tank yourself. The gases in the tank could be fatal!

access to, or near, the surface. This makes regular inspections, monitoring and maintenance easier.

Never enter the tank yourself. The gases in the tank,

such as methane and hydrogen sulphide, can be explosive or toxic to workers. An open flame or flashlight with more than two cells should not be used in or near a septic tank because of the danger from explosive gases. People have died of asphyxiation in septic tanks and sewers. The liquid in the tank should also be treated with respect. Sewage may contain bacteria, viruses or parasites that can make people sick.

The disposal field must also be properly cared for. The sod cover should be maintained to prevent erosion and reduce the amount of rainfall that enters the field. Large trees should be removed from the immediate area of the field to prevent roots from clogging the pipes, short-circuiting effluent to the surface or damaging the system (if the tree is uprooted).

It is important not to cover the field with a hard surface, such as concrete or asphalt or heavy clay material. Vehicles (cars, machinery, ATV's, snowmobiles) must NOT be allowed to run over any part of a disposal field since soil compaction, crushed distribution pipes, and damage to the field can result. Do not stack wood or build a shed or raised garden over your disposal system. The soil needs to breathe. For trouble-free operation, you should also control how much water you use and what goes down the drain.

Why and How Should I Conserve Water?

Water conservation shows good management. The minimum design capacity of a residential on-site system, which could

Conserving water will extend the life of your system.

include seasonal and rental units, is 1000 L/ day (220 g.p.d.). If you have a larger home, or if your home has fixtures that use additional water (such as hot tubs), or if you have a commercial establishment, you will need a system that is designed to receive more wastewater or problems can result. For example:

- The excess flow can wash out solids from the septic tank before they are treated or removed, damaging or clogging the disposal field.
- If excess flow is more than the field can disperse, the ground surface or your plumbing system may flood.

What Should Not Go Down the Drain?

An on-site system can handle all normal household wastes, including body wastes, wash water and laundry wastewater (including some bleach). However, some materials should not go down the drain because:

- an on-site system cannot treat them and they may contaminate water supplies or the environment.
- they will affect or slow down the performance of the system, and result in extra maintenance or require system replacement. Some materials that should not go down the drain are listed in Table 4.

Use commercial household and bathroom cleaners in moderation. They can damage your system.

Many people clean their toilets, sinks, showers and tubs with a mild detergent or baking soda. Do not use caustic drain openers for a clogged drain. Instead, use boiling water or a drain snake to open clogs. Consider using an environmentally friendly alternative product (Nova Scotia Environment has a pamphlet available).

Septic tank additives are not needed for proper operation of the tank. They may damage the system and contaminate groundwater. Some additives cause solids to wash from the septic tank into the disposal field. This is not recommended because the solids could clog the field.

Garbage grinders should not be used unless the size of the septic tank is increased by 20 percent to handle the extra solids.

Nova Scotia Environment does not recommend that you discharge backwash water from water treatment devices, to the on-site system, unless the system has been designed by a QP1 to handle the specified treatment system. If an existing treatment unit is hooked into the on-site disposal system, have a certified plumber to check the system for correct and safe installation. A proper air gap is required to prevent wastewater from backing up into the water supply.

What Should I do if a Problem Occurs

Keep a file folder readily available with a diagram of the system location, approval, and certificate of installation. If you cannot find your records, Nova Scotia Environment may have a copy of the approvals. If no records are available, start your own file.

Keep system information handy! If a problem occurs, your file is invaluable.

A problem or malfunction usually shows up in one of two ways:

- sewage backs up into the household plumbing.
- sewage or wet spots appear on top of the ground.

Troubleshooting usually begins in the household plumbing and proceeds towards the disposal field.

The House and Sewer Line

Sewage backup into the house, or even fixtures that drain slowly, may mean a physical blockage in the household fixtures themselves. If you have a toilet that won't flush properly or a drain that refuses to empty, start there. A plunger may free the toilet, or cleaning a drain trap may free the sink. These are simple checks you can do yourself.

If these simple measures do not work, hire a certified plumber to check for a physical blockage in the house. Common culprits include rags, diapers, children's toys, plastic bottles, and combination of congealed grease and lint from the washing machine.

If there is no blockage in the house, the next step is to check the building sewer line between the house and the tank. Common problems in the line include the culprits listed above, frost heave and settling, and broken pipe. Frost heave and settling may have altered the original slope on the sewer line, creating low spots where liquid can puddle and freeze during the winter months. This result in partial restriction or blockage. Alternatively, the pipe may have broken off completely due to settling after installation.

The Tank

If fixtures and sewer line are clear, the next step is usually to have a certified installer or certified septic tank cleaner inspect and pump your septic tank. Key trouble spots for blockage in the septic tank are the inlet and the outlet baffles or tees (Figure 5). It is important to check that the tank still has baffles. If these have broken down or broken off, scum and solids may have moved into the field and clogged it. If the problem is a blocked or crushed line leading to the tank, or blocked tank inlet or outlet, it will usually show up when the tank is inspected or pumped.

If pumping the tank does not solve the problem for more than a few days, or if raw sewage is discharging, the problem is likely in the disposal field. If pools of water are noticed in the field area, use water sparingly for a few days and check for improved performance.

The Field

Some common problems related to the field include overloading with water, clogging of some part of the system, or physical damage to the system. Check if any of these apply to your situation.

Increase in water load can result from:

- using fixtures such as hot tubs, jacuzzis, and spas
- concentrating water use, such as multiple washes in one day
- increasing family numbers or entertaining groups or visitors
- leaking plumbing fixtures
- running faucets to prevent freezing of pipes
- piping sink and laundry wastes directly to the field and bypassing the tank
- directing water from roofs, driveways and foundation drains into the system
- flooding by high groundwater table seasonally
- overloading of part of the field, or ponding and infiltration of surface water over part of the field
- poor design (too small for the flow)

Problems related to the pipes, rock, or soil can result from:

- poor design (system inadequately sized for the soil conditions)
- poor location with respect to the surrounding land or groundwater table such that the effluent cannot escape readily
- too much or too little slope on the distribution pipe within the field
- use of improper or inferior materials, such as imported sand fill or filter sand that does not meet specifications (usually permeability of soil is too low)
- construction during wet conditions, leading to smearing and reduction of natural soil permeability on the infiltrative surfaces

Problems related to physical damage can result from:

- compaction from vehicle traffic or landscaping activities
- paving, building, or storage of objects on top of the field
- tree roots
- carryover of scum and solids from the tank

If you have an emergency, such as sewage backing up into the house, and you cannot fix it yourself, call a certified installer. Depending on the specific cause(s) of your problem, you may need a QP involved to make further repairs or changes to the existing system, or to select or design a new system. You can also contact the nearest Nova Scotia Environment office (list at the back of this booklet) for advice on how to solve the problem.

How Can I Make My System Work Better?

Some ways to avoid failures and minimize malfunctions, in new and existing systems, include:

- Check and fix or replace leaking or slow draining plumbing fixtures regularly. Call a plumber if you cannot find the problem yourself.
- Spread out water use, do laundry (full loads) once a day or over the week rather than partial loads or several loads a day. Do dishwashing as the machine is full and spread out the loads. Use water-saving machines.
- When guests or parties will produce an extra load on the system, pump the tank before guests arrive. Use off-site facilities for excess laundry. Consider a timed-dose system. If the extra load is regular, you may need to expand the system.
- Reduce normal water use in showers and sinks: take short showers and turn off the water while brushing teeth.
- Use heat tape to prevent freezing of pipes rather than running water continuously.
- Install water conserving fixtures, such as low flow toilets
- Make sure that the septic tank is watertight so groundwater does not leak into it.
- Make sure that the system is located and protected to avoid unnecessary extra water from groundwater, surface water, roof, and foundation drains, interceptor drains, sumps, treatment unit backwash, and other sources.

Prospective and existing owners should consider two extra components that can improve system performance, make inspection of on-site systems easier, and help diagnose problems. These components are not required now, but they are inexpensive compared with the cost of the system, or with the cost of repairing or replacing it.

- Septic tank effluent filters shown in Figure 5 are designed to intercept solids that might otherwise escape from the tank and clog the field. Filters need regular cleaning usually when the septic tank is inspected or pumped. If they require more frequent cleaning, it is probable that the materials that blocked the filters would have reached the disposal field, causing potentially serious and expensive damage.
- A water meter will record your water use. You can compare use with the design flow of the system and detect leaking fixtures. The record will help you to make decisions about water conservation. Remember that if use is greater than the design flow rate, untreated effluent may surface down gradient of the field.

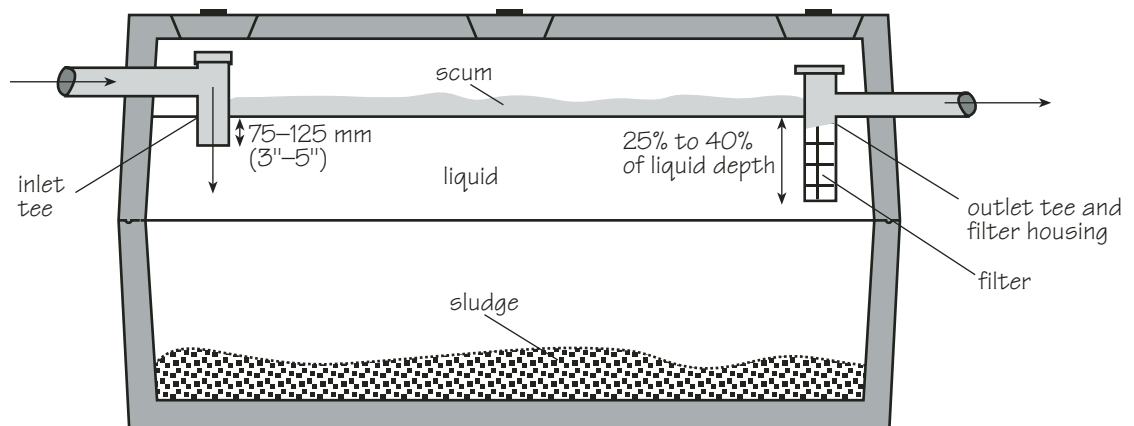

Figure 5 **Example of a Septic Tank Effluent Filter System**

Summary

Design, selection, construction and ownership of an on-site sewage disposal system are governed by the Environment Act and the On-site Sewage Disposal Regulations. Once the system is completed, the homeowner is responsible for proper care and maintenance of the system.

Some do's and don'ts are shown in Table 4. If you keep these in mind, your on-site system should provide good service for a long time.

Make sure that you record any repairs and maintenance work carried out on your system. A sample record form is shown in Appendix 3. This information is invaluable for future dealings with a contractor, a government agency, or a future purchaser of your home.

Table 4 **Some Do's and Don'ts to Keep in Mind**

Do's

- Do spread automatic washer use over the week rather than many loads on one day.
- Do make a permanent record of where the key parts of your system are located for future maintenance, such as tank pump outs or field repairs.
- Do have your septic tank pumped out regularly.
- Do keep records of pump outs and maintenance.
- Do use water conserving devices where possible. Low flush toilets and shower heads are commonly available.
- Do have manually cleaned lint traps on your automatic washer.
- Do check any pumps, siphons, or other moving parts of the system regularly
- Do remove or prevent trees with large root systems growing near the disposal field.
- Do maintain a healthy grass cover over the disposal field to use some of the water and to prevent erosion
- Do keep surface water from up slope or from roof drains away from the disposal field
- Do check your interceptor drain regularly to ensure that it is free flowing.
- Do compost your kitchen waste
- Do increase the size of your septic tank, and have it pumped more often, if a garbage grinder is to be installed.

Don't's

- Don't overload the system with high volumes of water.
- Don't connect basement sump pumps to the on-site system.
- Don't connect backwash from water treatment devices directly to the on-site system unless the system has been designed by a QP1.
- Don't allow large amounts of fats, chemicals, or solvents to enter the system; don't allow any plastics to enter.
- Don't use septic tank additives. They are not beneficial, and may damage your disposal system. Active bacteria are naturally present in sewage. Even with additives, regular pumping of solids is still required.
- Don't enter a septic tank without proper ventilation, a second person (adult) above ground, and other requirements for confined spaces. Sewer gases can be fatal.
- Don't allow vehicles or heavy equipment to drive over or park on the disposal field. This may compact the soil and crush the piping.
- Don't plant anything over the disposal field except grass; especially, don't cover the tank or field with asphalt or concrete or other impermeable material.
- Don't put in a separate pipe to carry wash waters to a side ditch or woods. This 'greywater' also contains disease carrying organisms
- Don't wait for signs of failure. Check the system regularly.
- Don't flush:

- coffee grounds	- dental floss	- paints
- disposable diapers	- kitty litter	- varnishes
- sanitary napkins	- tampons	- waste oil
- cigarette butts	- condoms	- poisons
- fats	- grease and oils	- paper towels
- thinners	- disinfectants	- pesticides
- photographic chemicals	- other chemical wastes	

References

Nova Scotia Environment and Labour. 1997. Before You Construct a Water Well. Report 68-3 (Fifth Revision 1997).

Nova Scotia Environment and Labour. 2007. Regulations Respecting On-site Sewage Disposal Systems. Approved by Order in Council, March 22, 2007, # 2007-173.

Nova Scotia Environment and Labour. 2007. On-site Sewage Disposal Systems Technical Guidelines. June 2007.

Appendix 1

Sample Form: **Application for Approval**



APPLICATION FOR APPROVAL

OFFICE USE ONLY		Application #	
Date Rec'd (yyyy/mm/dd)	Ext. Ref. #	NSEL File #	
Total Fees Due	Fees Paid	Paid in Full	Yes <input type="checkbox"/> No <input type="checkbox"/>
Receipt #	Water Auth. # (Div. 1 only)		

Nova Scotia Environment and Labour will only collect, use, and disclose personal information in keeping with the privacy provisions of the Nova Scotia Freedom of Information & Protection of Privacy Act (FOIPOP).

PLEASE PRINT OR TYPE. Complete Sections 1, 2, 3, 4 and 7 for ALL Applications. Complete areas of Sections 5 and 6 and the Submission Standard that are applicable to the specific activities of this application only.

Type of Application:			
New Application <input type="checkbox"/>	Renewal <input type="checkbox"/>	Amendment <input type="checkbox"/>	Transfer <input type="checkbox"/>
If applicable, provide the previous Approval #			

SECTION 1 - OWNER

If there is more than one owner, please indicate who will be the primary applicant for this project and attach a complete list of owners.

Company/Organization/Municipality					
Business Number (BN) if applicable					
Mr. <input type="checkbox"/>	Ms. <input type="checkbox"/>	Mrs. <input type="checkbox"/>	Other: <input type="checkbox"/>	Professional Designation	
First Name		Middle Initial	Family Name		
Phone	Home ()	Business ()	Ext.	Other ()	Ext.
Fax ()	E-mail				
Civic/Street Address					
Mailing Address (if different than Civic)					
County			City/Town		
Province	Postal Code		Country		

SECTION 2 - APPLICATION CONTACT

Is the Application Contact the same as Section 1 - Owner? Yes No If yes, please skip to Section 3.

Company/Organization/Municipality					
Business Number (BN) if applicable					
Mr. <input type="checkbox"/>	Ms. <input type="checkbox"/>	Mrs. <input type="checkbox"/>	Other: <input type="checkbox"/>	Professional Designation	
First Name		Middle Initial	Family Name		
Phone	Home ()	Business ()	Ext.	Other ()	Ext.
Fax ()	E-mail				
Civic/Street Address					
Mailing Address (if different than Civic)					
County			City/Town		
Province	Postal Code		Country		

SECTION 3 - SITE/LOCATION OF PROPOSED ACTIVITIES

Property Identification numbers (PID) are available at the Nova Scotia Department of Housing & Municipal Affairs.
1:50,000 Topo Maps (identifying Easting and Northing) are available at Nova Scotia Environment and Labour.

Subdivision Name		
Lot #		
Site Name		
Civic/Street Address		
County	Community	
Property Identification # (PID)	1:50,000 Topo Map #	
Grid Reference	Easting (6)	Northing (7)

SECTION 4 - ACTIVITY

Proposed Activity - Please check (✓) all that apply.

Activity	Complete Sections
On-site Sewage Disposal System <input type="checkbox"/>	4, 5A, 6, 7 and Submission Standard
Subdivision Proposal Report <input type="checkbox"/>	4, 5B, 6, 7 and Submission Standard

SECTION 5 - ACTIVITY DETAILS

Complete Section 5 to the best of your knowledge. Please provide measurements in the metric units indicated.

5A - Complete for all Individual Lot On-site Sewage only					
Sewage Disposal System	New <input type="checkbox"/>	Replacement <input type="checkbox"/>	Repair <input type="checkbox"/>	Modification <input type="checkbox"/>	Upgrade <input type="checkbox"/>
Malfunction Replacement	Yes <input type="checkbox"/>	No <input type="checkbox"/>			
Disposal Field Layout:					
C1 Contour <input type="checkbox"/>	C1 Raised <input type="checkbox"/>	C2 Contour <input type="checkbox"/>	C2 Raised <input type="checkbox"/>		
C3 Contour <input type="checkbox"/>	Mound <input type="checkbox"/>	Holding Tank <input type="checkbox"/>	Sloping Sand Filter <input type="checkbox"/>		
Area Bed <input type="checkbox"/>	At Grade <input type="checkbox"/>	Partially Trenched <input type="checkbox"/>	Fully Trenched <input type="checkbox"/>		
Multiple Trench <input type="checkbox"/>	At Grade <input type="checkbox"/>	Partially Trenched <input type="checkbox"/>	Fully Trenched <input type="checkbox"/>		
Peat System <input type="checkbox"/>	Other <input type="checkbox"/>	if other, please specify:			
Type of Development:					
Residential: Single Family <input type="checkbox"/>	Residential: Multiple Unit <input type="checkbox"/>	Commercial <input type="checkbox"/>	Industrial <input type="checkbox"/>		
Institutional <input type="checkbox"/>	Other <input type="checkbox"/>	if other, please specify:			
Design Capacity (litres/day)					
Assessment Report completed by:	QP1 <input type="checkbox"/>	QP2 <input type="checkbox"/>	Department <input type="checkbox"/>		
Name of Qualified Person:	Certificate #		APENS #		
Variation Requested	Yes <input type="checkbox"/>	No <input type="checkbox"/>			

5B - Request for Written Response for a Subdivision Proposal (Response only - no Approval issued)

Proposed Number of Lots:

SECTION 6 - SUPPORTING DOCUMENTATION TO ATTACH

All supporting documentation is to be submitted in accordance with the "Approvals Procedures Regulations." If applicable, the following documents must be submitted with this Application; however, additional information may be requested.

Note: A legend must be supplied for all mapping describing symbols used, scale and north orientation.

Attach for All applications	
<input type="checkbox"/>	Copy of the property deed, lease or letter proving the applicant's legal right to conduct the activity on the site
<input type="checkbox"/>	Submission Checklist
<input type="checkbox"/>	Copy of subdivision, surveyor's or plot plan
<input type="checkbox"/>	Qualified Person's Assessment Reports

If information submitted is incomplete, or if supporting documentation is of poor quality (plans, maps, etc.), the application may be delayed, returned or rejected.

SECTION 7 - DECLARATION

Correspondence is to be returned to:	Owner <input type="checkbox"/>	OR	Application Contact <input type="checkbox"/>
--------------------------------------	--------------------------------	----	----------------------------------------------

Owner's Signature _____	Date (yyyy/mm/dd) _____
Name (Please print or type) _____	

<p>OWNER'S AUTHORIZATION (If Correspondence Is to Be Returned to Application Contact)</p> <p>If you are acting on behalf of the owner, you must:</p> <ol style="list-style-type: none"> 1. Have the Owner sign above <u>or</u> Attach a letter of authorization from the Owner identified on Page 1, Section 1, of this application. 2. Identify yourself as the Application Contact on Page 1, Section 2, of this application. 3. Sign the declaration below. <p>I certify that I am acting with the owner's full consent.</p> <p>Signature _____ Date (yyyy/mm/dd) _____</p> <p>Name (Please print or type) _____</p>

Sample Form: **Submission Standards for Applications Form**

SUBMISSION STANDARD

All applications must comply with the Act, Regulations, Guidelines and any policies within the Department. A completed copy of this form must accompany each application.

APPLICANTS NAME: _____ APPLICATION #: _____

SUBDIVISION NAME: _____ LOT NUMBER: _____

SOIL EVALUATION TESTS							
TEST PIT PROFILE (M)				Evaluation Date: _____			
TOTAL DEPTH:	_____	m	SOIL STRATUM	SOIL TYPE	DEPTH OF SOIL (mm)	DENSITY	MOISTURE
BEDROCK AT:	_____	m	ORGANIC	organic mat			
WATER TABLE:	_____	m	1 st layer				
SLOPE:	_____	%	2 nd layer				
ROOTS TO:	_____	m	3 rd layer				
MOTTLING AT:	_____	m	4 th layer				

Permeability of soil in-situ:	_____	m - meter
Flow rate:	_____	1 meter = 1000 mm
Test method:	_____	mm - millimeter (1 mm = 0.001 meter)
All measurements should be calculated from the top of the test pit.		

SYSTEM SELECTION CRITERIA				
Daily flow	Permeable soil type	Depth of permeable soil	Slope	Soil permeability (In-situ test)
litres/day: _____	_____	mm: _____	%: _____	m/s: _____

SYSTEM SELECTION FROM TECHNICAL GUIDELINES				
Type of Disposal Field:	_____	Imported sand fill required	<input type="checkbox"/> YES	<input type="checkbox"/> NO
Distribution Trench	Length: _____ m	Permeability Rate	_____ m/sec	
Dimensions:	Width: _____ m			
Cut at Toe of Trench:	_____ mm	Width of Buffer - downslope	_____ m	
		- upslope	_____ m	
Interceptor Trench	<input type="checkbox"/> YES <input type="checkbox"/> NO depth: _____ mm	Depth of Buffer (at 5 m from trench)	_____ mm	
Liner:	<input type="checkbox"/> YES <input type="checkbox"/> NO thickness: _____ mm			
Pump or Siphon Capacity	_____ litres	Septic Tank Capacity	_____ litres	
Watertight Testing:	<input type="checkbox"/> YES <input type="checkbox"/> NO	Watertight Testing:	<input type="checkbox"/> YES <input type="checkbox"/> NO	

Actual Clearance Distances**								
From Nearest	To System	To Tanks*	From Nearest	To System	To Tanks*	From Nearest	To System	To Tanks*
Lot Boundary	m	m	Cistern	m	m	Water Distribution	m	m
Downslope Boundary	m	m	Watercourse	m	m	Foundation Drain	m	m
Drilled Well	m	m	Wetland	m	m	Other	m	m
Dug Well	m	m	Intermittent Drain	m	m	Other	m	m

* The shortest distance from any of the following: septic tank, pump or siphon chamber and effluent pipe

** Enter actual distance, or N/A or > 60 meters

SUBMISSION STANDARD

All applications must comply with the Act, Regulations, Guidelines and any policies within the Department. A completed copy of this form must accompany each application. (A separate sketch or drawing may be utilized provided it includes the requested information).

SITE EVALUATION OF LOT/ PROPOSED SYSTEM

Sketch of lot, showing location of soil evaluation test pits, direction of slope, watercourse and other features that may influence the selection or design of the system on the lot or **within 60 meters of any part of the proposed system** including a sketch of proposed On-site Sewage Disposal System Selection/Design*. **The test pit and proposed system location is shown in reference to two fixed points on the property and is within 6 meters plus or minus of the system location. The placement of the system must at all times meet the minimum clearance distances in the regulations unless a variance is specified in the terms and conditions of the Approval. If this application is for the replacement of a malfunctioning system; show the location of the existing system.**

* Cross sectional diagrams of proposal to be attached to this form for submission.

DATE: _____ QUALIFIED PERSON: _____ (SIGNATURE)
 CERTIFICATE OF QUALIFICATION/APENS #: _____ (PRINT NAME)

SCHEDULE C Raised C2

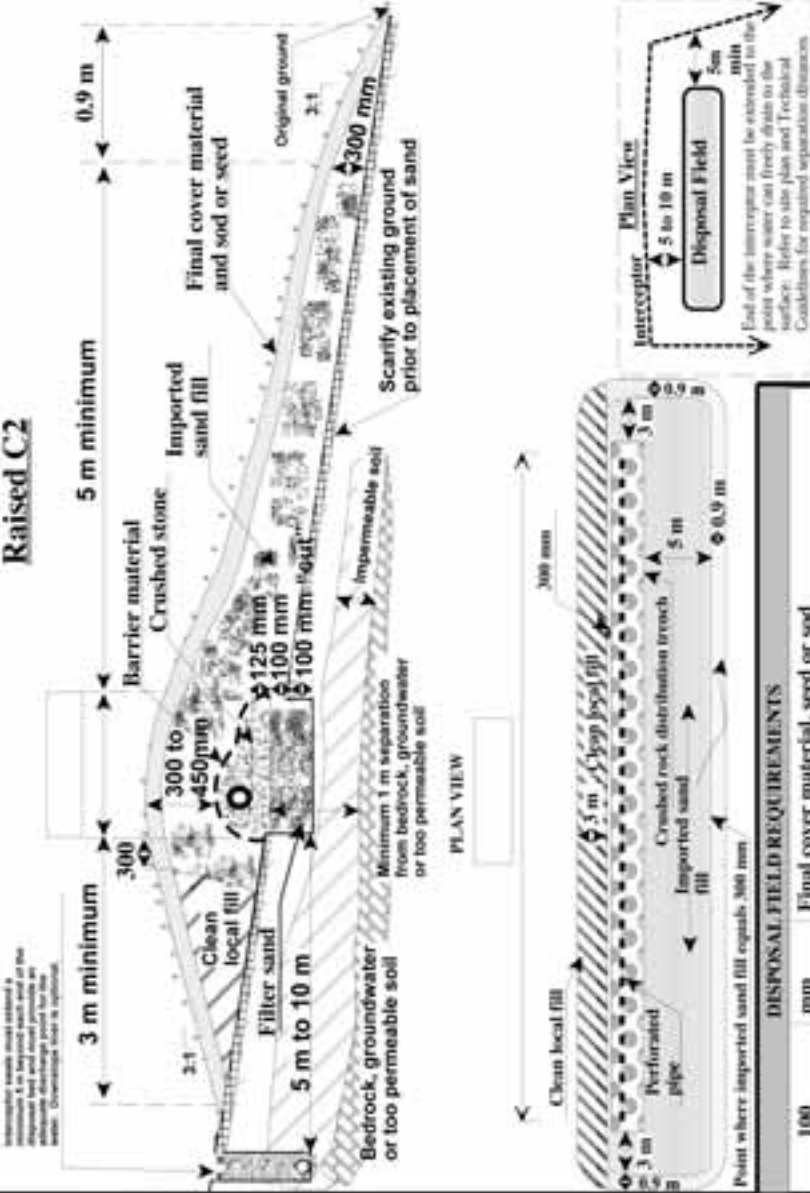

General Conditions

Contractor shall verify location of all wells, watercourses, lot boundaries and all elevations prior to construction (within 30.5 m from the location of disposal system)

Backwash water from water treatment devices must not be discharged to the on-site sewage disposal system unless the system is designed by a professional engineer.

Roof, foundation and lot drainage must be directed away from the disposal field, septic tank and pump (siphon) chamber.

Steps must be taken to ensure that the proposed disposal field area is not subject to vehicular traffic or any other disturbance such as excavation or stockpiling of excavated material etc., Installation of physical barrier is recommended.

It is the applicant's responsibility to assure that the construction of foundations, driveway, well or any other development on the lot will not impact on the feasibility of on site sewage disposal field installation.

Disposal System must be installed by a contractor licensed to install on-site sewage disposal systems in Nova Scotia.

All work must be completed in accordance with the Nova Scotia On-Site Sewage Disposal Systems Regulations, On-Site Sewage Systems Technical Guidelines, and conditions of the Approval.

Selection Criteria:	NOT TO SCALE
Flow (l/d):	Applicant:
Slope (%):	Approval No.:
Soil type:	Location:
Soil depth (mm):	Qualified Person:

DISPOSAL FIELD REQUIREMENTS	
100	mm Final cover material, seed or sod
200 to 350	mm Imported sand fill
Required over crushed rock	
75	mm Barrier material
	mm Crushed rock above pipe
	mm Perforated pipe diameter
	m Perforated pipe length
125	mm Crushed rock below pipe
200	mm Filter sand / Permeability m/s: <input type="checkbox"/> Minutes at 20°C
	m Interceptor/Swale depth <input type="checkbox"/> Yes <input type="checkbox"/> No
	m/s Imported sand fill permeability <input type="checkbox"/> Minutes at 20°C

Appendix 2

Sample Form: **Certificate of Installation Form**



NSEL Approval # _____

CERTIFICATE OF INSTALLATION FORM

INTERIM REPORT

FINAL REPORT

APPROVAL HOLDER	SYSTEM INSTALLER	QUALIFIED PERSON
Name:	Qualification #:	Qualification #:
Address:	Name:	Name:
	Address:	Address:
Postal Code:	Postal Code:	Postal Code:
Phone No.:	Phone No.:	Phone No.:

Lot: _____ Location: _____

C - COMPLIANT	N - NON COMPLIANT	NA - NOT APPLICABLE	NP - NOT IN PLACE
TYPE OF SYSTEM: <input type="checkbox"/> C1 <input type="checkbox"/> C1 Raised <input type="checkbox"/> Standard C2 <input type="checkbox"/> C2 Raised <input type="checkbox"/> C3 <input type="checkbox"/> Mound <input type="checkbox"/> Holding Tank	<input type="checkbox"/> Sloping Sand Filter <input type="checkbox"/> Area Bed <input type="checkbox"/> Multiple Trench <input type="checkbox"/> Pear <input type="checkbox"/> Other (Specify) _____		

SKETCH OF DISPOSAL SYSTEM
 (Please identify separation distances to wells, watercourses and property boundaries. The location of the disposal field and septic tank must be shown in reference to two fixed points on the property.)

System Specifications	
System length _____	Meters
System width _____	Meters
Pipe quality <input type="checkbox"/> C <input type="checkbox"/> N <input type="checkbox"/> NA	
Pipe slope <input type="checkbox"/> C <input type="checkbox"/> N <input type="checkbox"/> NA	
Crushed rock <input type="checkbox"/> C <input type="checkbox"/> N <input type="checkbox"/> NA	
Excavation <input type="checkbox"/> C <input type="checkbox"/> N <input type="checkbox"/> NA	
Interceptor ditch <input type="checkbox"/> C <input type="checkbox"/> N <input type="checkbox"/> NA	
Barrier material <input type="checkbox"/> C <input type="checkbox"/> N <input type="checkbox"/> NA	
Imported fill <input type="checkbox"/> C <input type="checkbox"/> N <input type="checkbox"/> NA	
Septic Tank <input type="checkbox"/> C <input type="checkbox"/> N <input type="checkbox"/> NA	
Holding Tank <input type="checkbox"/> C <input type="checkbox"/> N <input type="checkbox"/> NA	
Watertight <input type="checkbox"/> C <input type="checkbox"/> N <input type="checkbox"/> NA	
Pump Chamber <input type="checkbox"/> C <input type="checkbox"/> N <input type="checkbox"/> NA	
Watertight <input type="checkbox"/> C <input type="checkbox"/> N <input type="checkbox"/> NA	
Siphon <input type="checkbox"/> C <input type="checkbox"/> N <input type="checkbox"/> NA	
Tested <input type="checkbox"/> C <input type="checkbox"/> N <input type="checkbox"/> NA	
Pump <input type="checkbox"/> C <input type="checkbox"/> N <input type="checkbox"/> NA	
Tested <input type="checkbox"/> C <input type="checkbox"/> N <input type="checkbox"/> NA	
Alarm Present <input type="checkbox"/> C <input type="checkbox"/> N <input type="checkbox"/> NA	
Backfill <input type="checkbox"/> C <input type="checkbox"/> N <input type="checkbox"/> NA <input type="checkbox"/> NP	
Final Cover Mat <input type="checkbox"/> C <input type="checkbox"/> N <input type="checkbox"/> NA <input type="checkbox"/> NP	
Seed/Sod <input type="checkbox"/> C <input type="checkbox"/> N <input type="checkbox"/> NA <input type="checkbox"/> NP	

ACTUAL CLEARANCE DISTANCES (M - METERS)								
From Nearest	To System	To Tanks	From Nearest	To System	To Tanks	From Nearest	To System	To Tanks
Lot Boundary	M	M	Cistern	M	M	Water Distribution	M	M
Downslope Boundary	M	M	Watercourse	M	M	Foundation Drain	M	M
Drilled Well	M	M	Wetland	M	M	Other	M	M
Dug Well	M	M	Intermittent Drain	M	M	Other	M	M

Approval Holders Water Supply: Drilled Well Dug Well Municipal Proposed Existing
 Cistern Surface Water Other _____

Completion of Work Form Attached: Yes No

INTERIM REPORT ONLY

Signature of Qualified Person: _____ Date of Inspection: _____
 The system was installed between October 1 and April 1, as a result it is not possible to place the final cover material, and it would be impractical to sod or seed the field. All work with the exception of the final cover (backfill, final cover material, and seed/sod) has been completed in accordance with the On-Site Sewage Disposal Systems Regulations and complies with the approval issued. The disposal system has been protected from erosion. All damages will be repaired prior to the placing of final cover material and sod or seeding. The work will be completed by June 30, 20____, and a Final Certificate of Installation Form will be submitted.

Signature of Approval Holder: _____ Date: _____
 Signature of Installer: _____ Date of Installation: _____

FINAL REPORT ONLY

Signature of Qualified Person: _____ Date of Inspection: _____
 Signature of Installer: _____ Date of Installation: _____

Nova Scotia Environment and Labour will only collect, use, and disclose personal information in keeping with the privacy provisions of the Nova Scotia Freedom of Information & Protection of Privacy Act (FOI/PA).

Revised: June, 2007

Appendix 4

Sample Form: **Completion of Work Form for On-site Sewage Disposal System Installers**



NSEL Approval # _____

COMPLETION OF WORK FORM FOR ON-SITE SEWAGE DISPOSAL SYSTEM INSTALLERS

Name of Approval Holder: _____ Qualified Person: _____

Location of Property: _____ Lot Number: _____

Municipality: _____ PID: _____

The following applies to a Septic Tank(s) or a Holding Tank(s)			
Yes	No	N/A	
<input type="checkbox"/>	<input type="checkbox"/>	<input type="checkbox"/>	The tank has been installed in accordance with manufactures recommended procedures
<input type="checkbox"/>	<input type="checkbox"/>	<input type="checkbox"/>	The tank has been sized as per the approval
The following items have been installed in accordance with the approval:			
<input type="checkbox"/>	<input type="checkbox"/>	<input type="checkbox"/>	Pipe
<input type="checkbox"/>	<input type="checkbox"/>	<input type="checkbox"/>	Barrier Material
<input type="checkbox"/>	<input type="checkbox"/>	<input type="checkbox"/>	Crushed Rock
<input type="checkbox"/>	<input type="checkbox"/>	<input type="checkbox"/>	Imported Sand Fill
<input type="checkbox"/>	<input type="checkbox"/>	<input type="checkbox"/>	Filter Sand
<input type="checkbox"/>	<input type="checkbox"/>	<input type="checkbox"/>	Interceptor/Swale
<input type="checkbox"/>	<input type="checkbox"/>	<input type="checkbox"/>	Pump Chamber/Siphon Chamber
<input type="checkbox"/>	<input type="checkbox"/>	<input type="checkbox"/>	Pump
<input type="checkbox"/>	<input type="checkbox"/>	<input type="checkbox"/>	Alarm
<input type="checkbox"/>	<input type="checkbox"/>	<input type="checkbox"/>	Final Cover Material
<input type="checkbox"/>	<input type="checkbox"/>	<input type="checkbox"/>	Seed or Sod, if no, installer to notify owner of requirement

I have installed this system in accordance with the Approval, the *On-site Sewage Disposal Systems Regulations* and the *On-site Sewage Disposal Systems Technical Guidelines*.

Installer's Signature: _____

Print Name _____

Qualification #: _____

Date: _____

Revision: April 3, 2007

Notes or Sketches



Notes or Sketches

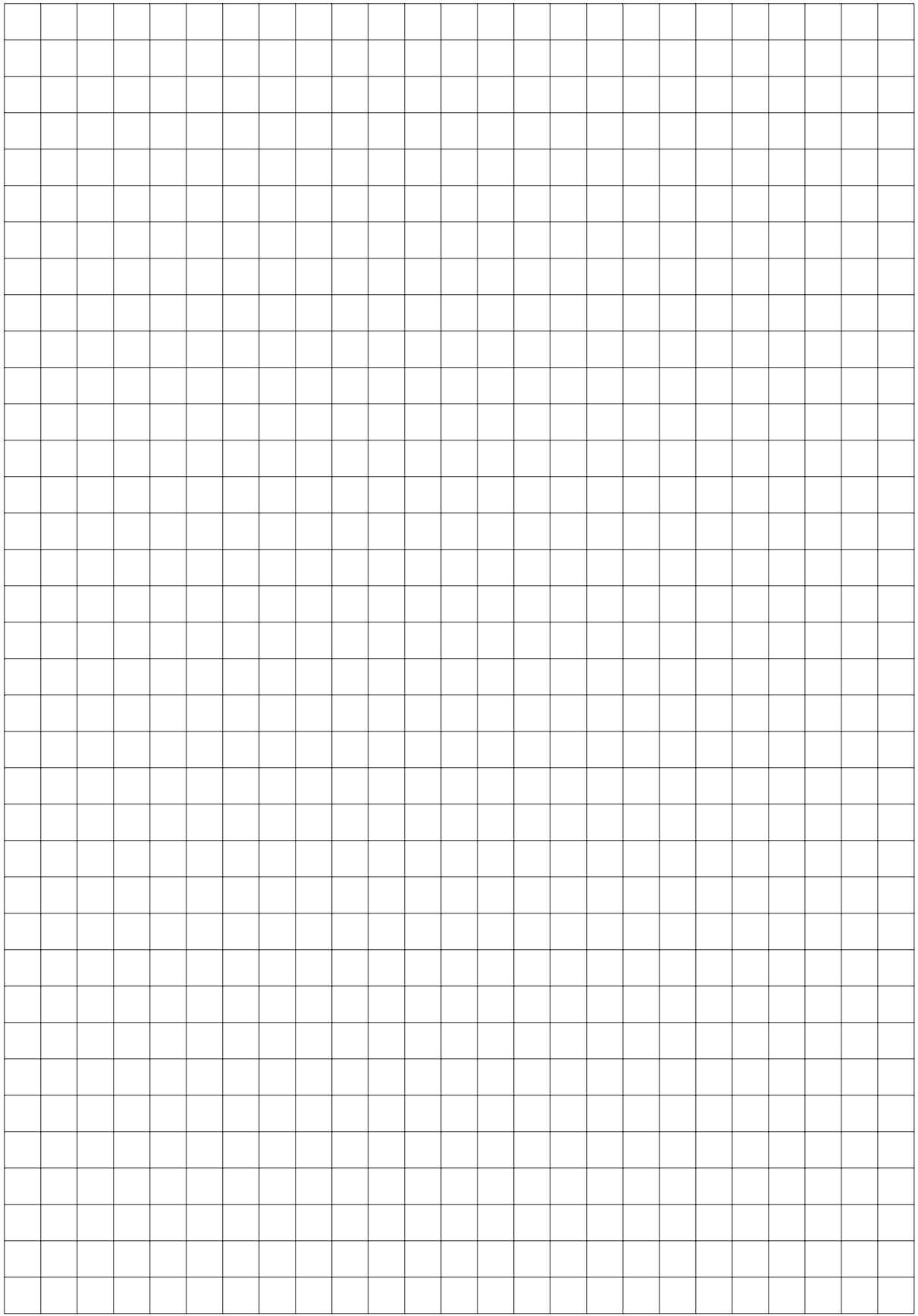

Notes or Sketches

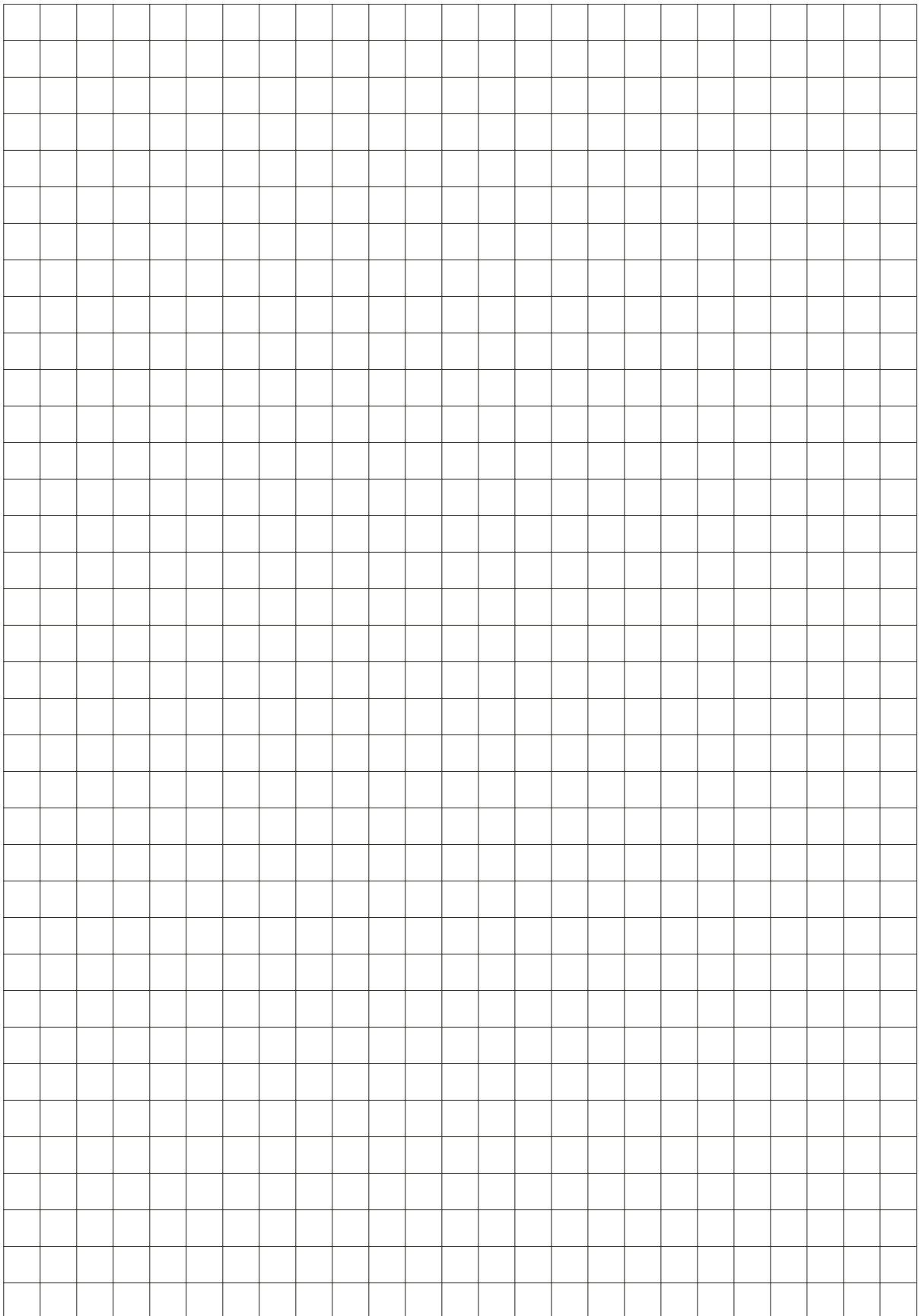

Nova Scotia Environment Regional Offices

REGION	STREET AND MAILING ADDRESS	TELEPHONE NO.	FAX NO.
Central Region Bedford	1595 Bedford Highway Suite 224, Sunnyside Mall Bedford, NS B4A 3Y4	(902) 424-7773	(902) 424-0597
Sheet Harbour	Fire Hall, 22835 Highway #7 PO Box 35 Sheet Harbour, NS B0J 3B0	(902) 885-2462	(902) 885-2743
Northern Region Truro	36 Inglis Place, 2nd Floor PO Box 824 Truro, NS B2N 5G6	(902) 893-5880	(902) 893-0282
Pictou	20 Pumphouse Road, Granton PO Box 675 New Glasgow, NS B2H 5C6	(902) 396-4194	(902) 396-4765
Amherst	71 East Victoria Street 2nd Floor Amherst, NS B4H 1X7	(902) 667-6205	(902) 667-6214
Antigonish	155 Main Street, Suite 205 Antigonish NS B2G 2B6	(902) 863-7389	(902) 863-7411
Western Region Kentville	136 Exhibition Street, 2nd Floor Kentville NS B4N 4E5	(902) 679-6088	(902) 679-6186
Bridgewater	60 Logan Road Bridgewater NS B4V 3J8	(902) 543-4685	(902) 527-5480
Yarmouth	13 First Street Yarmouth NS B5A 2S9	(902) 742-8985	(902) 742-7796
Eastern Region Sydney	295 Charlotte Street PO Box 714 Sydney, NS B1P 6H7	(902) 563-2100	(902) 563-2387
Port Hawkesbury	218 MacSween Street, Suite 12 Port Hawkesbury, NS B9A 2J9	(902) 625-0791	(902) 625-3722